



**BE SERIES ELECTRONIC PLC TEST BENCH
OPERATORS MANUAL**



SAFETY PRECAUTIONS



READ INSTRUCTIONS AND IDENTIFY ALL COMPONENT PARTS BEFORE OPERATING BENCH

TEST BENCH PRODUCES EXTREMELY HIGH PRESSURE. USE CAUTION WHEN OPERATING

KEEP HANDS AWAY FROM PINCH POINTS

CONSULT HOSE AND FITTING MANUFACTURER'S SPECIFICATIONS FOR CORRECT TESTING PROCEDURE

ALWAYS WEAR EYE PROTECTION

BE Series Test Bench models available:

BE1500PLC Series: 1500 bar (21,500psi)

BE2500PLC Series: 2500 bar (37,500psi)

BE3500PLC Series: 3500 bar (50,000psi)

Operation is similar for all models with the exception of the maximum pressure.

**For Parts and Service, Contact:
Custom Machining Services, Inc.
Valparaiso, In 46383
(219) 462-6128**

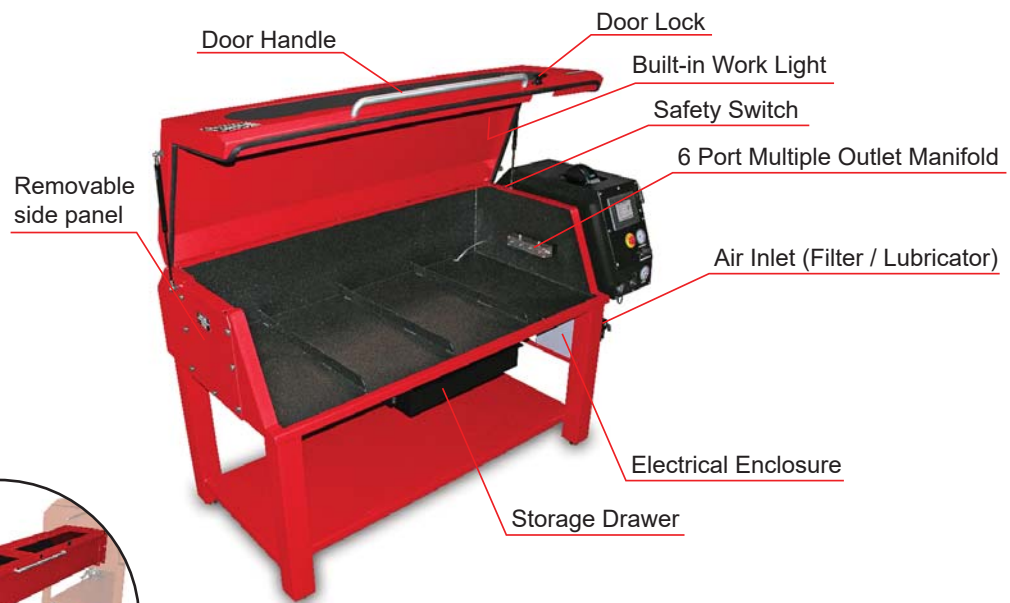

Available Extension Trough

TEST BENCH CONNECTIONS

- Connect a water supply hose to the water inlet connection which is located at the rear of the control cabinet.
- Connect a water drain hose to the water drain connection located at the rear of the test bench. Run the drain line to an appropriate drainage area.
- Connect an air supply (80 psi Min) to the air inlet/filter, and make certain that the lubricator is filled with oil. This must be checked periodically to assure proper operation of the pump.

Note: for optimum performance an air supply of 28 SCFM is recommended.

- Plug the electrical cord into a standard 110VAC outlet.

TEST BENCH OPERATION

- Prior to operating bench, make sure that pressure regulator knob is adjusted all the way out (counterclockwise).

- Follow the screen prompts to input test parameters.

- Raise the tank lid and connect hose to be tested to the high pressure manifold.

- Note: The manifold port threads are a special high-pressure coned configuration that only accepts the proper mating fittings. (Adapters are available to connect various thread sizes to the manifold.)

- Secure the supplied plugs in unused manifold ports.

- It is recommended that a high pressure bleed valve be installed on the free end of the hose for purging air out of the lines.

- Open the bleed valve and fill the hose with water.

- Close the bleed valve when the hose is filled with water.

- Place supplied rubber safety mat over hose.

- Lower tank lid and make sure latch engages to ensure it is fully closed.

- Adjust the air pressure regulator such that the maximum test pressure can be achieved. If the air pressure is set to a higher pressure than required to achieve the hose test pressure there is a danger that the pump may overshoot the test pressure.

- Follow screen prompts to set up and start actual tests.

- When the test cycle is complete, disconnect the hose and drain the remaining water from the hos





After the system initializes and loads, the "Begin Test" screen will appear.



Press New Test to initiate a test or Repeat Test to repeat the previous test.



Press the pressure button to bring up the pressure adjustment keypad screen.

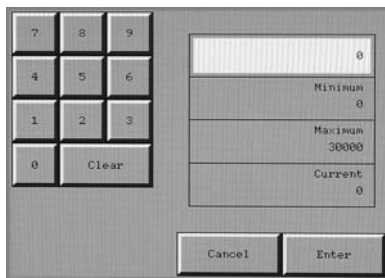

Enter the max test pressure. Keypads will pop up for settings not indicated by arrows as shown on the next screen.

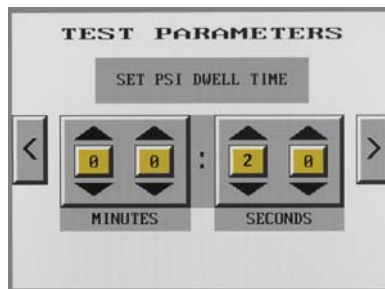

Set the time for the hose to be held at test pressure.

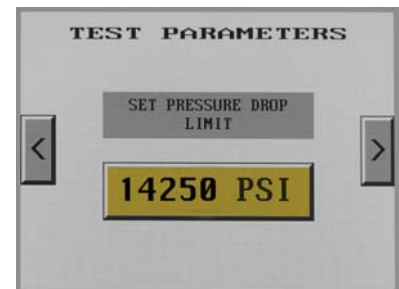

Enter the minimum pressure allowed during the test cycle.

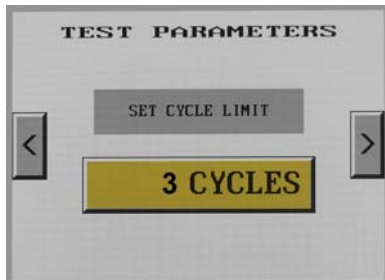

Enter the number of times that the test is to be run.

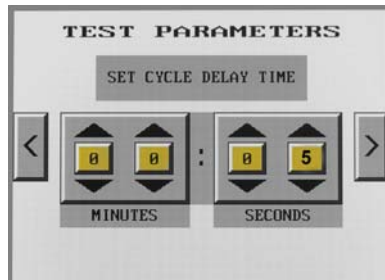

Enter the delay time between test cycles.

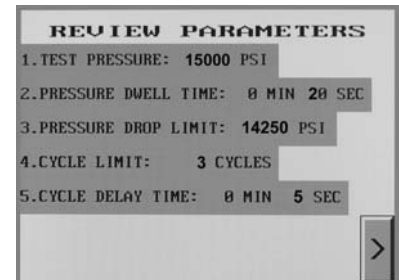

Review test parameters prior to running test.



If test parameters and test setup is correct, start test.

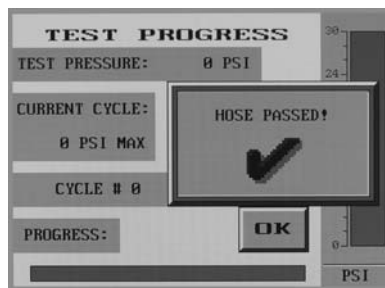

Test progress is shown.

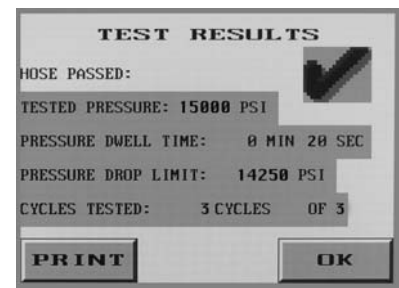

Test results are shown and the print option is available.



From the main screen, select Options.

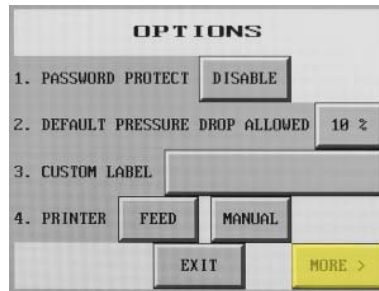

Select More from the Options menu.

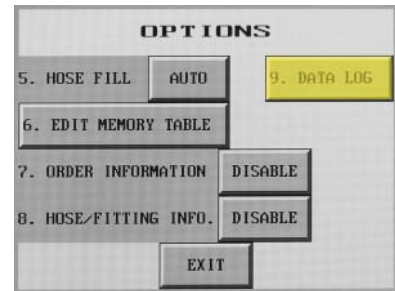

Select Data Log from the second Options screen.

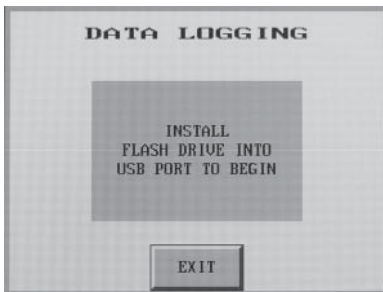

Following instructions on the screen, Install Flash Drive.



Press Start Transfer once the unit is ready. (Screen will flash briefly)



Select Remove USB once transfer completes. Exit and remove Flash Drive from control panel.

#	Date	ORDER #	TEST PSI	CURRENT	DWELL - I	DWELL - S	CURRENT PSI	DROP CYCLE	CC CYCLE	LP DELAY	N DELAY
2	6/3/2010 9:53	12368	1000	1036	0	10	1000	900	0	5	0
3	6/3/2010 9:53	12368	1000	1216	0	10	1168	900	1	5	0
4	6/3/2010 9:53	12368	1000	1165	0	10	1122	900	3	5	0
5	6/3/2010 9:53	12368	1000	1102	0	10	1064	900	3	5	0
6	6/3/2010 9:54	12368	1000	1079	0	10	1026	900	4	5	0
7	6/3/2010 9:54	132	1500	1541	0	10	1501	1350	0	2	0
8	6/3/2010 9:55	132	1500	1546	0	10	1500	1350	1	2	0
9	6/3/2010 9:59	658	2000	2095	0	10	2037	1800	1	10	0
10	6/3/2010 9:59	658	2000	2087	0	10	2024	1800	3	10	0
11	6/3/2010 10:00	658	2000	2115	0	10	2060	1800	5	10	0
12	6/3/2010 10:00	658	2000	2109	0	10	2046	1800	7	10	0
13	6/3/2010 10:00	658	2000	2085	0	10	2019	1800	9	10	0
14	6/3/2010 10:01	658	850	1140	0	10	1090	765	0	10	0
15	6/3/2010 10:01	658	850	1111	0	10	1077	765	1	10	0
16	6/3/2010 10:02	658	850	938	0	10	893	765	2	10	0
17	6/3/2010 10:02	658	850	887	0	10	858	765	3	10	0
18	6/3/2010 10:08	9453	600	713	0	4	671	540	0	10	0
19	6/3/2010 10:08	9453	600	687	0	4	639	540	1	10	0
20	6/3/2010 10:08	9453	600	637	0	4	599	540	2	10	0
21	6/3/2010 10:08	9453	600	665	0	4	625	540	3	10	0
22	6/3/2010 10:08	9453	600	670	0	4	626	540	4	10	0
23	6/3/2010 10:08	9453	600	672	0	4	636	540	5	10	0
24	6/3/2010 10:08	9453	600	670	0	4	627	540	6	10	0

Log files will be saved on USB drive. Using a computer, locate the EA_LogCopy folder to view data. A separate file will be saved and labeled for each day. Information is most compatible with a program like Microsoft Excel. Test results will be stored and formatted as shown above.

There are informational, adjustment and warning screens programmed into the software. While most are self explanatory, a brief description is given below.

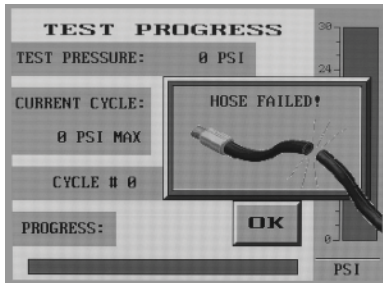

If the test does not complete satisfactorily, the Hose Failed screen will appear.

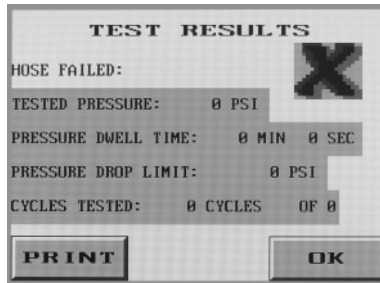

This screen details the cause of the failed test.

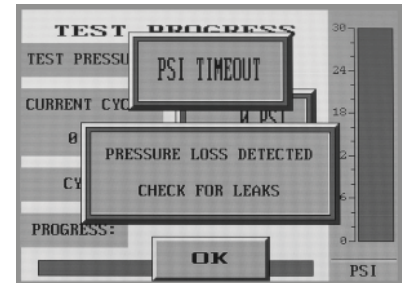

Test cycle was unable to finish due to pressure leaks.



Emergency stop is depressed.

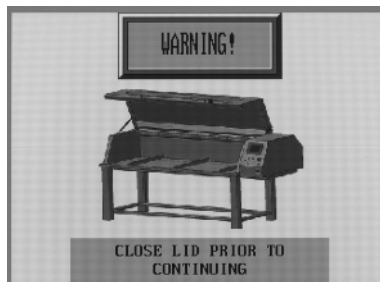

Test bench lid is not properly closed and latched.

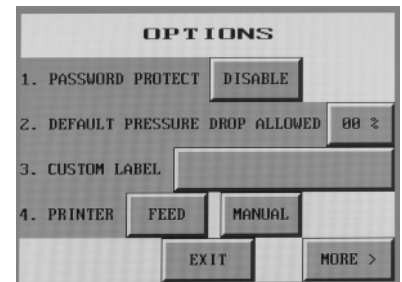

From the Main Menu Options screen, default parameters can be set.

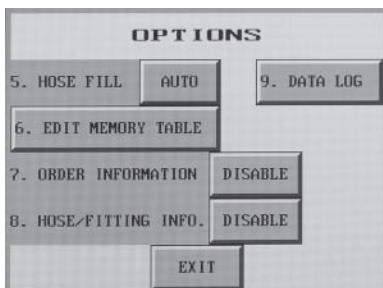

Access to the memory table and adjustments to the print tape can be found here.

ADJUSTING THE PRESSURE RELEASE VALVE

(Refer as Hipco Valve)

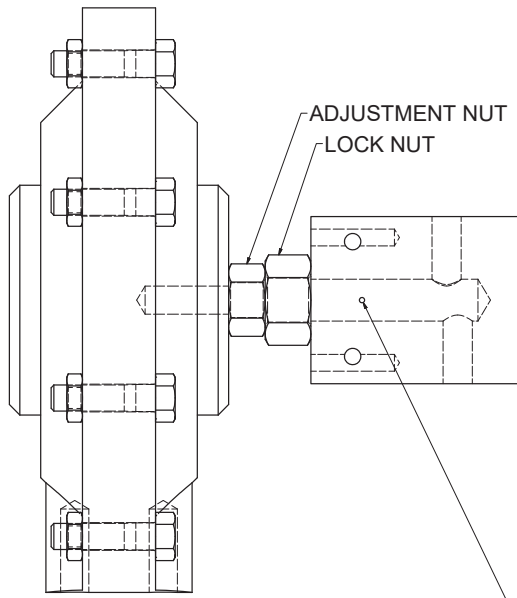

- Follow the instructions on page 9-10.

WEEP HOLE.
IF PACKING IS NOT
TIGHT ENOUGH, WATER
WILL COME OUT THIS HOLE.

1). Disconnect the Air Line.

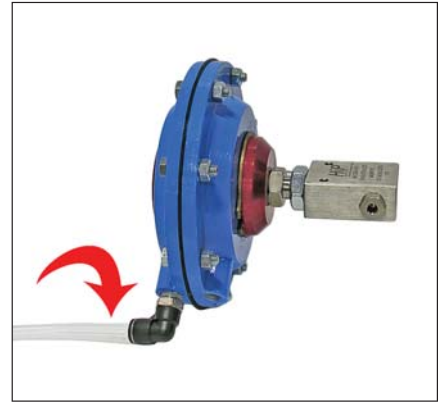

2). Use a 1" wrench to grab the Adjustment Nut and with a 1-1/8" wrench to loosen the Lock Nut, until spins freely.

(Adjustment Nut will be closest to Blue Diaphragm).



3). Rotate the Blue Diaphragm counter-clockwise to remove it from the Block.



4). Clean the Blue Diaphragm Needle and apply grease. Remove the Packing from the block and clean them. Place the Packing on the Blue Diaphragm Needle.

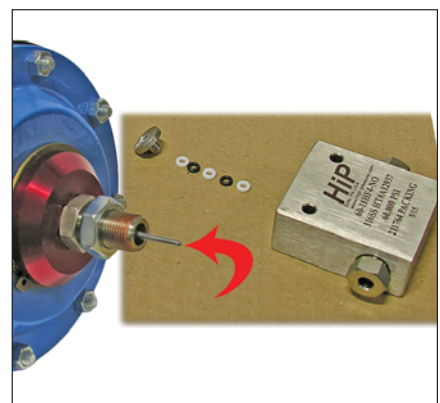

- 5). The Packing must follow the order as shown.
Apply grease all over the packing.



- 6). Place the Blue Diaphragm Needle (Packing installed) into the Block and rotate the Blue Diaphragm clockwise until you can feel the packing (Seals) make contact with the valve cone.

Note: Do not tighten past this point, damage to stem and packing can occur. Tightening past this point will begin to compress the packing and will also make the stem stick again.



- 7). Use a 1 inch wrench to grab the Adjustment Nut and with a 1-1/8" wrench to tighten the Lock Nut. (Just snug tight).



- 8). Connect the Air Line back into the fitting and test out the unit to check the adjustment.

- If water comes out of weeping hole than go back to step 6 and snug stem slightly more.

Note: The objective is to tighten the Adjustment Nut so that the packing seals around the needle and still allows the Blue Diaphragm to move the needle back and forth to build pressure and drain.

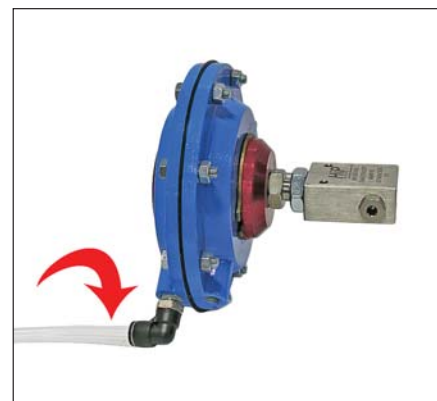



1/4" NPT P/N:103687-04



3/8" NPT P/N:103687-06



1/2" NPT P/N:103687-08



3/4" NPT P/N:103687-12



1/2" JIC P/N:104428-08



3/8" JIC P/N:104428-06



2WAY NEEDLE VALVE P/N:104352



5000 PSI RELIEF VALVE P/N:104642



RELIEF VALVE P/N:104241



REPAIR KIT P/N:104241-KIT



AIR REGULATOR P/N:104115



MANIFOLD BLOCK P/N:102100



BE 1500 PUMP P/N:103860



BE 2500 PUMP P/N:103861



BE 3500 PUMP P/N:103862



CustomCrimp “No-Nonsense” Warranty Statement

All CustomCrimp Products are warranted to be free of defects in workmanship and materials for one year from the date of installation. This warranty ends when the product becomes unusable for reasons other than defects in workmanship or material.

Any CustomCrimp Product proven to be defective in workmanship or material will be repaired or replaced at no charge. To obtain benefits of this warranty, first, contact Warranty Repair Department at Custom Machining Services at **(219) 462-6128** and then deliver via prepaid transportation the complete hydraulic product to:

**ATTN: WARRANTY REPAIR DEPT.
Custom Machining Services, Inc.
326 North Co. Rd 400 East
Valparaiso IN 46383**

If any product or part manufactured by CustomCrimp is found to be defective by CustomCrimp, at its option, CustomCrimp will either repair or replace the defective part or product and return via ground transportation, freight prepaid. **Custom Crimp will not cover any incoming or outgoing freight charges for machines sold outside The United States.**

This warranty does not cover any product or part which is worn out, abused, altered, used for a purpose other than for which it was intended, or used in a manner which was inconsistent with any instructions regarding its use.

Electric motors are separately warranted by their manufacturer under the conditions stated in their separate warranty.

Custom Crimp®
Custom Machining Services, Inc.
326 N. County Rd. 400 East
Valparaiso, IN 46383
Ph: (219) 462-6128
Fax: (219) 464-2773
www.customcrimp.com



CustomCrimp®

See the complete line of CustomCrimp® Crimpers and Accessories at:
www.customcrimp.com

(219) 462-6128
